

E-Z ANCHOR INSTALLATION METHOD

Note: With machine installation, a Minute-Man adapter designed to fit both the anchor head and drive machine shaft is available. Installers do not need additional or special equipment for E-Z Anchor Installation.

E-Z Anchors are a patented item.

1. MACHINE INSTALLATION

The drive machine is started and the anchor is turned into the ground to a point where the top (stabilizer head plate) is flush with or slightly below ground level. This assures that the E-Z Anchor Stabilizer will be at its required installation position. **See Figure A.**

To achieve full potential, install the E-Z Anchor vertically. A 10° deviation from vertical is acceptable. **See Figure A.**

Note: A slightly greater angle may be used to start anchor to avoid contact with the home and straightened as anchor is ground set. The splitbolt is inserted, strap is fastened, and tightening adjustment made.

E-Z Anchor carries U.S. Patents and manufacture is exclusive to Minute-Man Anchors, Inc.

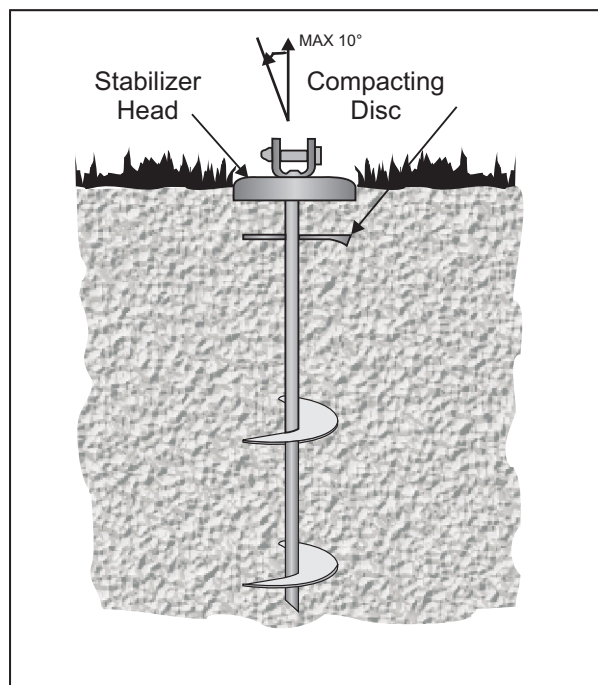

Figure A

2. STANDARDS FOR INSTALLATION

- E-Z Anchors and all components are to be installed per manufacturer's instructions.
- E-Z Anchors are approved for designated Soil Class III.
- E-Z Anchor working load capacity is 3,150 pounds for a single tie or the load of (2) ties combined.. **See Figure B.**
- Consult manufactured home set up instructions for number of frame tie downs, over the roof tie downs and tie down spacing.
- Proper site preparation requires removal of grass and sod prior to installation.

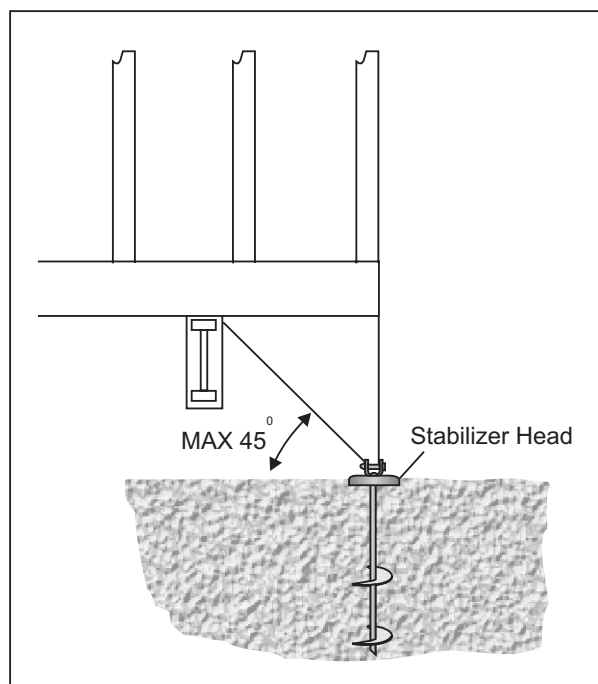

Figure B

For additional information, copies of engineering test(s) and report, Contact Minute-Man Anchors, Inc. (Revised: November 1998)